

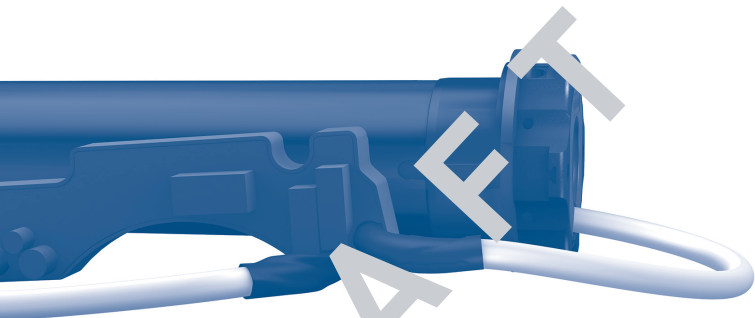

## INSTA SHORT ZRX



MOTORE DOPPIA RADIO CON REGOLAZIONE AUTOMATICA  
DEL FINECORSO ELETTRONICO

**IT**

DUAL RADIO MOTOR WITH AUTOMATIC ADJUSTMENT  
OF THE ELECTRONIC LIMIT SWITCH

**EN**

DUAL-FUNKMOTOR MIT AUTOMATISCHER EINSTELLUNG  
DER ELEKTRONISCHEN ENDLAGEN

**DE**

MOTEUR À DOUBLE COMMANDE RADIO AVEC RÉGLAGE  
AUTOMATIQUE DES FINS DE COURSE ÉLECTRONIQUES

**FR**

MOTOR RADIO DUAL CON REGULACIÓN AUTOMÁTICA  
DEL FIN DE CARRERA ELECTRONICO

**ES**





**Table of contents:**

How to prepare the motor .....	p. 36
Electrical connections .....	p. 37-38
Compatible remote controls .....	p. 39
Key to symbols .....	p. 40
Command sequences example .....	p. 41
Function open/close programming remote control .....	p. 42-43
Operational modes .....	p. 44
Setting the first remote control .....	p. 44
Automatic disabling of the first remote control setting function .....	p. 44
Setting the rotation direction of the motor .....	p. 45
Limit switches and obstacle detection .....	p. 46
Limit switches auto-calibration .....	p. 46
Middle position .....	p. 47
Restoring the factory settings .....	p. 48
Setting of additional remote controls .....	p. 48
Deleting a single remote control .....	p. 48
Total deletion of the remote controls memory .....	p. 49
Special functions:	
Short-term setting of a remote control .....	p. 50
Setting the A530058 pocket remote control .....	p. 51
Electric wiring to motor command for UP-DOWN MODE (2 independent UP-DOWN buttons) .....	p. 52
Command management from white wire UP-STOP-DOWN-STOP / UP-DOWN / UP-DOWN "DEAD MAN" .....	p. 53

## Table of contents:

<b>USING THE MOTOR INTO A Z-WAVE™ NETWORK</b> .....	p. 54
Device description .....	p. 54
Z-Wave™ technical specification .....	p. 54
Device installation.....	p. 55
Inclusion/exclusion the device into/from a Z-Wave™ network (classic).....	p. 55
STANDARD inclusion (inclusion/exclusion).....	p. 56
SMARTSTART inclusion .....	p. 57
S2 SECURE inclusion .....	p. 57
Device control .....	p. 58
Controlling the motor by remote and external switches .....	p. 58
Controlling the motor with a Z-Wave™ controller.....	p. 59
Reset to the factory settings .....	p. 60
Firmware update .....	p. 60
<b>ADVANCED SETTINGS</b>	
Supported command classes.....	p. 61
“COMMAND_CLASS_BASIC” support.....	p. 62
“COMMAND_CLASS_INDICATOR” support.....	p. 62
“COMMAND_CLASS_NOTIFICATION” support.....	p. 62
Associations.....	p. 63
Configurations .....	p. 64
EU Declaration of conformity.....	p. 158

## MOTOR INSTALLATION: MAIN STEPS

- Installing the motor into the rolling shutter .....	p. 36
- Wired connections .....	p. 37-38
- Connecting the remote control .....	p. 44
- Setting the limit switches.....	p. 46
- Connecting to the Z-Wave™ system .....	from p. 64

## HOW TO PREPARE THE MOTOR

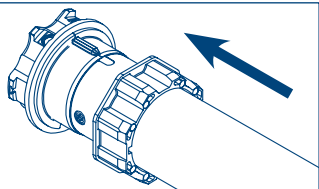
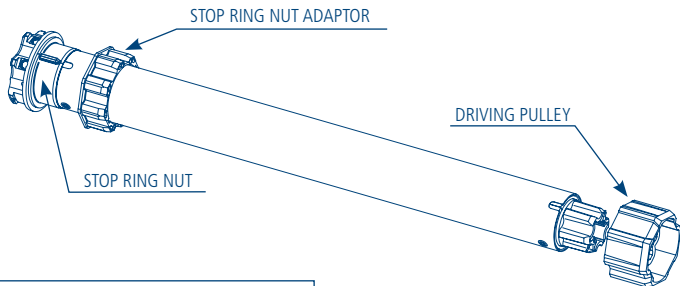

1. Insert the adaptor in the stop ring nut mating the groove with the reference notch and push till they touch.

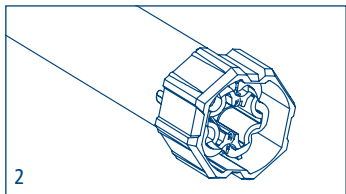

2. Fix the driving pulley on the motor pin until the stop pin clicks.

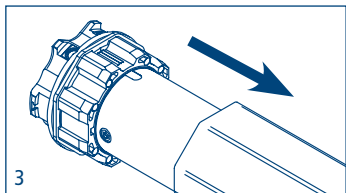

3. Insert the motor fully in the rolling tube.

**NB:** If you use tubes with a round form, the driving pulley must be fixed to the tube, and the installation is to be paid by the person who installs the system. For other tube sections the fitting is optional, but strongly recommended.

## ELECTRICAL CONNECTIONS

- To prevent any danger or malfunction, the size of electrical control components connected to the motor must be compatible with the electrical features of the motor.
- Means for disconnection must be incorporated in the fixed wiring in accordance with the national installation standards.
- The selectors inverting the direction of rotation of the motor must be provided with mechanical interlocking.
- **NEVER** connect two or more selectors to the same motor.
- For outdoor use, provide the appliance with a supply cord with designation H05RN-F containing at least 2% of carbon.
- To avoid short circuits, arrange an automatic bipolar switch with opening distance of the contacts of at least 3 mm before the circuit.
- If not used, the white wire must be insulated. It is dangerous to touch the white wire when the motor is powered.

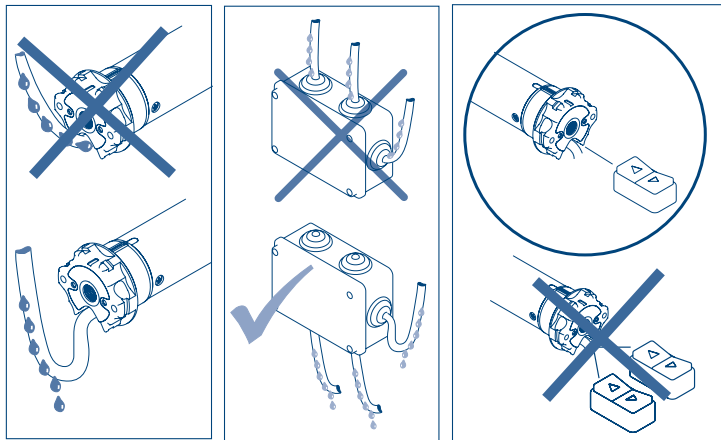

# ELECTRICAL CONNECTIONS



ENGLISH

Series GIRO

Series SKIPPER

Series POP

230 V 50 Hz

230 V 50 Hz



- 1 - NEUTRAL
- 2 - PHASE
- 3 - WIRED SWITCH (WHITE)
- PE - EARTH

- ① BLUE
- ② BROWN
- ③ WHITE (WIRED SWITCH)
- Ⓟ YELLOW-GREEN

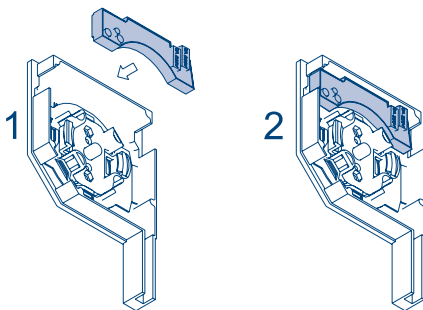

## COMPATIBLE REMOTE CONTROLS

### GIRO

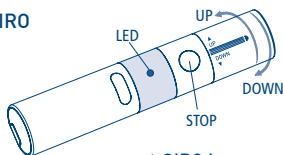

### GIRO Wall

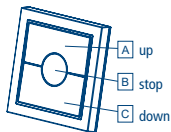

### GIRO Plus

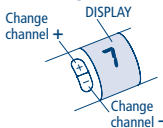

### GIRO Lux

Activating the Sun sensor

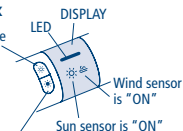

Deactivating the Sun sensor

### GIRO P-Lux

Change channel

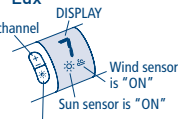

Activating/ Deactivating the Sun sensor

### POP

### POP Lux

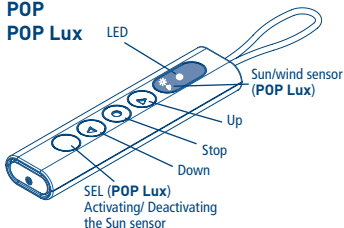

### POP Plus

### POP P-Lux

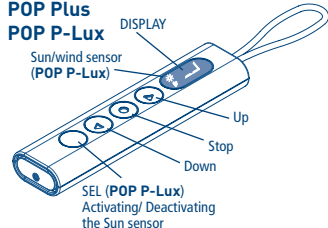

SKIPPER  
SKIPPER Lux  
SKIPPER Plus  
SKIPPER P-Lux

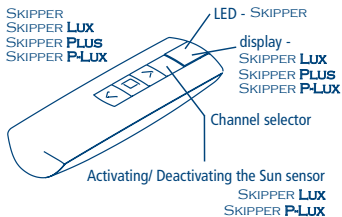

SKIPPER LCD  
SKIPPER SENSO

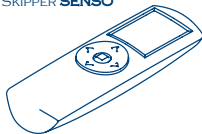

Check the specific instruction book

A530058 Remote Control with 4 independent channels





## KEY TO SYMBOLS

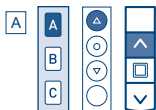
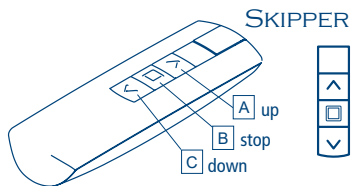
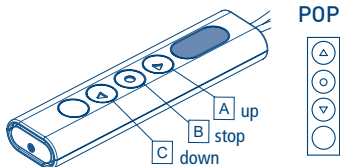
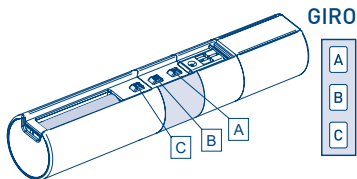
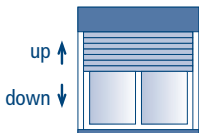

Press button A

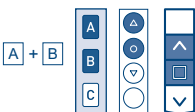

Press buttons A and B  
at the same time



Press the  
bottom  
UP



Press the  
bottom  
DOWN



Release



short motor rotation  
in one direction



long motor rotation  
in other direction



double short  
rotation

## COMMAND SEQUENCES EXAMPLE

Most of the command sequences have three distinct steps, at the end of which the motor indicates if the step has been concluded positively or not, by turning in different ways. This section is provided to demonstrate the motor indications. The buttons must be pressed as shown in the sequence, without taking more than 4 seconds between one step and the next. If more than 4 seconds are taken, the command is not accepted and the sequence must be repeated.

Command sequence example:

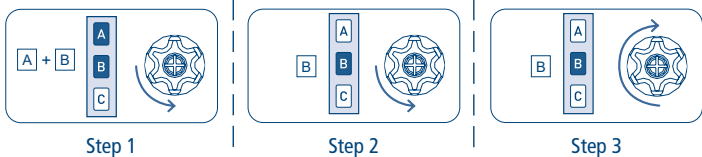

As we can see from the example, when the sequence ends positively, the motor returns to its starting position in one long rotation. In fact, two short rotations in the same direction correspond to one long rotation in the opposite direction. The motor returns to the starting position even when the sequence is not completed; in this case by performing one or two short rotations.

Example of a wrong sequence:

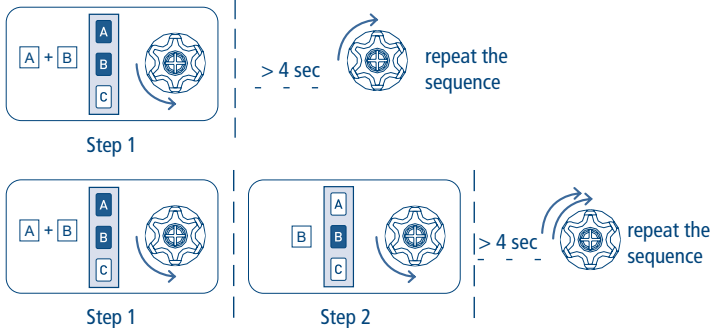

# FUNCTION OPEN/CLOSE PROGRAMMING

## REMOTE CONTROL SKIPPER PLUS - SKIPPER LUX - SKIPPER P-LUX

## REMOTE CONTROL POP PLUS - POP LUX - POP P-LUX

To prevent accidental changes to the programming of the motor during the daily use of the remote control, the possibility of programming is disabled automatically 8 hours after sending the last sequence (A+B or B+C).

### CHECKING THE STATUS OF THE FUNCTION

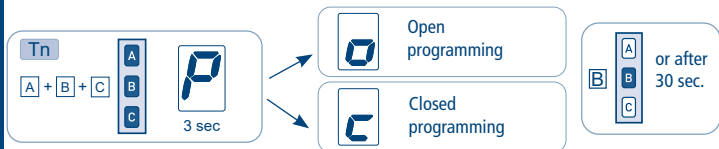

To change the status of the function, see the sequences "ENABLE/DISABLE PROGRAMMING".

### ENABLE PROGRAMMING

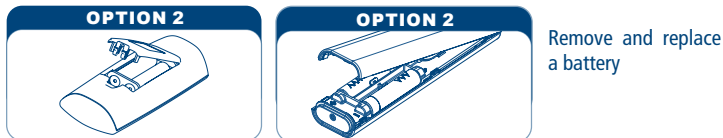

Proceed with programming as the instructions booklet.

### DISABLE PROGRAMMING



## FUNCTION OPEN/CLOSE PROGRAMMING

### REMOTE CONTROL SKIPPER - SERIES GIRO - REMOTE CONTROL POP

To prevent accidental changes to the programming of the motor during the daily use of the remote control, the possibility of programming is disabled automatically 8 hours after sending the last sequence (A+B or B+C).

#### CHECKING THE STATUS OF THE FUNCTION

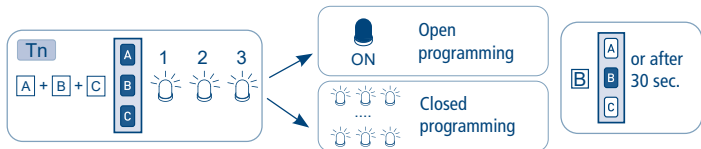

To change the status of the function, see the sequences "ENABLE/DISABLE PROGRAMMING".

#### ENABLE PROGRAMMING

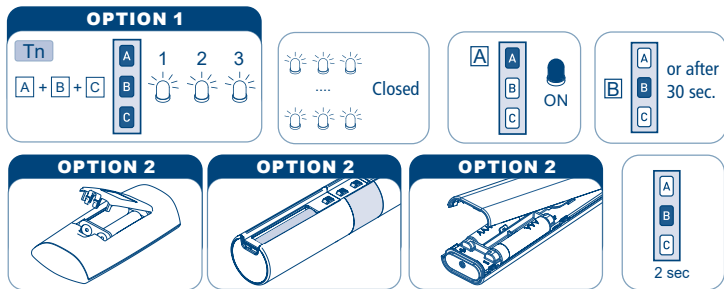

Remove one battery and wait minimum 5 seconds or press any button.

Proceed with programming as the instructions booklet.

#### DISABLE PROGRAMMING



## OPERATIONAL MODES

The tubular motor is very simple to be used and installed, it does not need any regulation as it automatically detects the position of limit switch.

The rolling shutter must be equipped with:

- security locks or stiff fixing springs,
- fixed or removable stoppers for end slats.

It is very important to check the sturdiness of the rolling shutter.

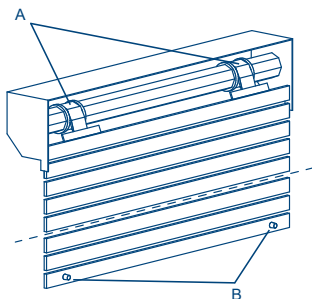

### SETTING THE FIRST REMOTE CONTROL

This operation can only be performed when the motor is new, or after a total delete of the memory.

**During this step, power up only one motor at time!**

T1: First remote control to be set

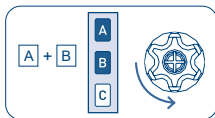

T1

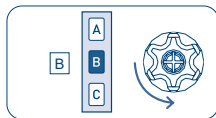

T1

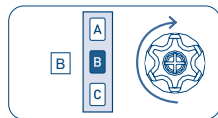

T1 (2 sec)

### AUTOMATIC DISABLING OF THE FIRST REMOTE CONTROL SETTING FUNCTION

Every time you connect the power supply to the motor, you have 3 hours to store the first remote control. After this time, the ability to store the remote control is disabled. To reset the timer of the function you have to disconnect and reconnect the power supply to the motor.

## SETTING THE ROTATION DIRECTION OF THE MOTOR

The operation can be performed via remote control or using the white wire. Every time you perform one of the two sequences below you reverse the output direction of the motor.

### From the remote control:

Tn: Already programmed remote control

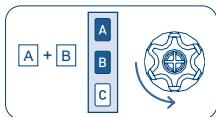

Tn

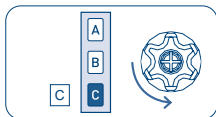

Tn

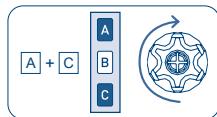

Tn (4 sec)

### From the wired control:

The sequence of this operation is the following:

- 1) Disconnect the power supply from the motor, via the main switch for example.
- 2) Connect the white motor wire to the brown wire (phase) or to the blue wire (neutral).
- 3) Connect the power supply to the motor, which rotates briefly in one direction.
- 4) Disconnect the power supply from the motor for at least 4 seconds.
- 5) Connect the motor to the power supply, after about 2 seconds the motor performs a short rotation up or down. Within 3 seconds disconnect the power supply, for example using the main switch.
- 6) Disconnect the white wire from the motor.

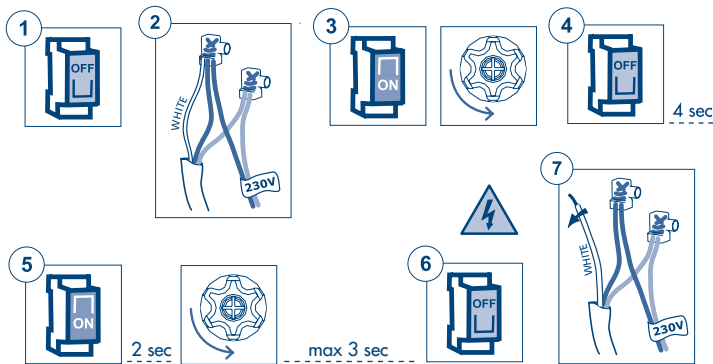

## LIMIT SWITCHES AND OBSTACLE DETECTION

After having memorized the first remote control and properly assigned the rotation direction (see page 45), the motor is ready for operation.

Run two complete ascent and descent cycles with the A and C buttons on the remote control or execute the limit switches auto-calibration command (see next paragraph) to memorise the operating times required for correct use by Z-Wave™ applications.

In the event an obstacle is detected, the motor performs a reverse relaxation movement.

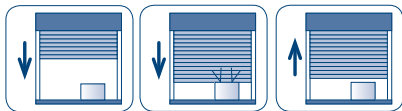

## LIMIT SWITCHES AUTO-CALIBRATION

Tn: Already programmed remote control

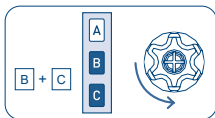

Tn

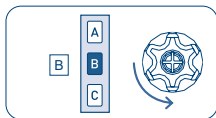

Tn

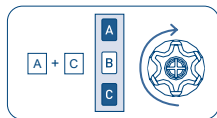



Tn (2 sec)

At the end of the sequence, the motor performs 2 complete Up/Down cycles to save the limit switches of the rolling shutter.

## MIDDLE POSITION

This optional function allows the rolling shutter to be adjusted to a favourite middle position. The middle position is memorized as a descent time starting from the high limit switch.

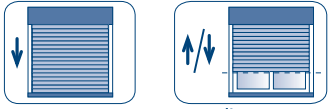
### SETTING MIDDLE POSITION

Procedure	Command sequence
<p><b>1) Press the A+B buttons for at least 2 s.</b></p> <p><i>The motor will immediately perform a brief confirmation movement and, after 2 s, it will restart to descend again.</i></p>	 <p>(2 sec)</p>
<p><b>2) Wait for the roller shutter to lower completely.</b></p> <p><i>The motor is now running in dead man mode, enabling the fine adjustment of the middle position.</i></p>	 <p>Adjustment</p>
<p><b>3) Confirm the position pressing B for 2 s.</b></p>	 <p>(2 sec)</p>

### MOVEMENT MIDDLE POSITION

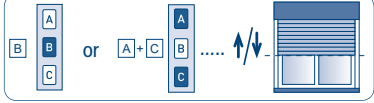
Procedure	Command sequence
<ul style="list-style-type: none"> <li><b>While the motor is stopped, give a long stop command (&gt;2s).</b> <i>After two seconds, the motor performs intermediate positioning.</i></li> <li><b>Give an A+C pulse while the motor is stopped.</b> <i>The motor performs the intermediate positioning.</i></li> </ul>	 <p>(2 sec)</p> <p>Positioning</p>

### DELETING MIDDLE POSITION





## RESTORING THE FACTORY SETTINGS

Tn: Already programmed remote control

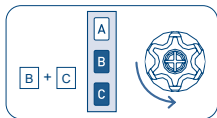

Tn

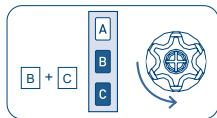

Tn

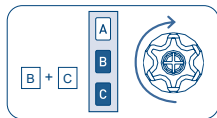

Tn (4 sec)

## SETTING OF ADDITIONAL REMOTE CONTROLS

Up to 15 remote controls can be set.

Tn: Already programmed remote control

Tx: Additional remote control

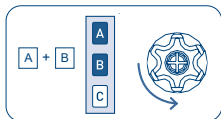

Tn

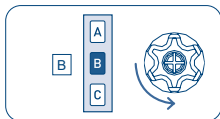

Tn

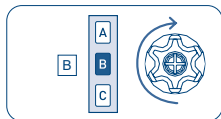

Tx (2 sec)

## DELETING A SINGLE REMOTE CONTROL

All stored remote controls can be deleted individually. When the last one is deleted, the motor's initial condition is restored. The same applies to the individual channels of a multi-channel remote control: simply select the channel to be deleted before executing the sequence.

Tn: Remote control to be cleared

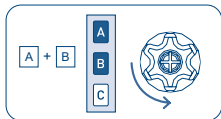

Tn

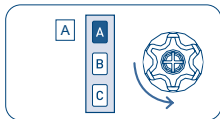

Tn

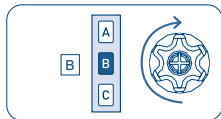

Tn (2 sec)

# TOTAL DELETION OF THE REMOTE CONTROLS MEMORY

The full memory clearing can be performed in two ways:

## 1) WITH THE REMOTE CONTROL

Tn: Already programmed remote control

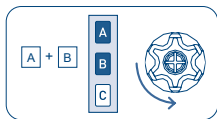

Tn

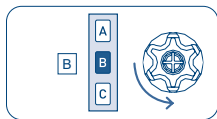

Tn

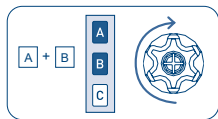

Tn (4 sec)

## 2) WITH THE WHITE WIRE

Do this operation only in case of emergency, if all remote controls are no longer operating. To delete the memory we have to access the white wire of the motor.

The sequence of this operation is the following:

- 1) Disconnect the power supply from the motor, via the main switch for example.
- 2) Connect the white motor wire to the brown wire (phase) or to the blue wire (neutral).
- 3) Connect the power supply to the motor, which rotates briefly in one direction.
- 4) Disconnect the power supply from the motor for at least 4 seconds.
- 5) Connect the motor to the power supply, after about 2 seconds the motor performs a short rotation up or down. After about 6 seconds the motor performs a long rotation in the opposite direction.
- 6) Disconnect the power supply from the motor.
- 7) Separate the white wire from the brow/blue wire. Insulate the white wire, in an appropriate way, before reconnecting the power supply.

At this point it is possible to proceed with the setting of the first remote control.

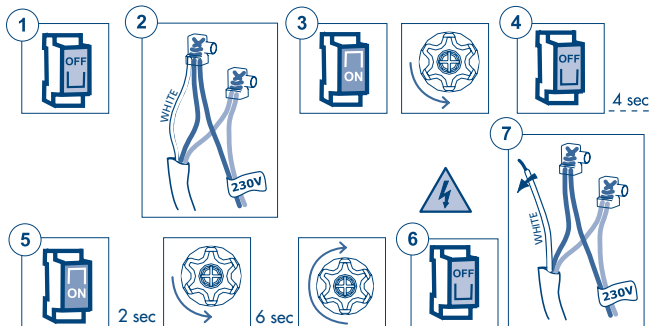

## SPECIAL FUNCTIONS

### SHORT-TERM SETTING OF A REMOTE CONTROL

This function makes it possible to store a remote control temporarily, for example, with the purpose of setting the limit switches during assembly in the factory. A later final saving of the remote control will be possible using the appropriate command sequence (see: "SETTING THE FIRST REMOTE CONTROL"). The operations described below can be carried out only when the motor has just come out of the factory or after a full memory clearing (see: "FULL MEMORY CLEARING"). The motor makes the following operations possible only within the time limits described in order to make sure that the short-term setting is used only in the installation or factory setting phase and not during daily use. Power up the motor, make sure that no other motors having an empty memory are powered up in the same operating range.

**Within 30 seconds after start**, press the B and C buttons simultaneously until the motor gives a confirmation signal.

**The remote control will remain stored for 5 minutes**, while the motor is powered up. After 5 minutes or when the motor has its power cut off, the remote control will be cancelled.

T1: First remote control to be set

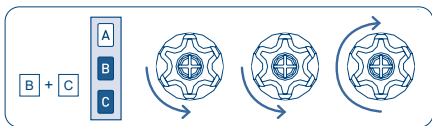

T1

## SETTING THE A530058 POCKET REMOTE CONTROL

NB: The pocket remote control can only be set up after programming a previous remote control such as the traditional Cherubini remote controls (Skipper, Giro or POP - 3-button Up-Down-Stop remote control).

### HOW TO PROCEED TO SET THE BUTTON ON THE POCKET REMOTE CONTROL

Tn: Already programmed remote control

Tx: Pocket remote control to be set

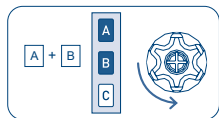

Tn

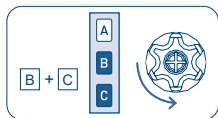

Tn

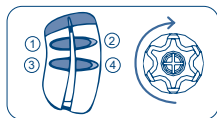

Tx (2 sec)

In the last step of the sequence, press the desired button on the pocket remote control for 2 seconds. The remote control can now control the motor in stepping mode (UP - STOP - DOWN - STOP). To associate the other buttons, repeat the sequence described above. Each button can be associated with one INSTA SHORT ZRX motor.

### DELETING ONE BUTTON ON THE POCKET REMOTE CONTROL

The buttons saved may be deleted individually according to the following sequence:

Tn: Already programmed remote control

Tx: Pocket remote control with button to be deleted

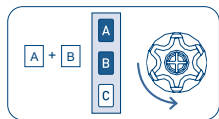

Tn

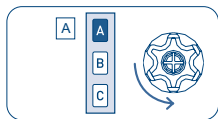

Tn

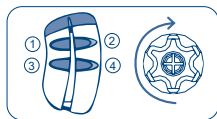

Tx (2 sec)

The motor will perform a confirmation movement and the function associated with the button just pressed (for 2 sec) will be removed.

## ELECTRIC WIRING TO MOTOR COMMAND FOR UP-DOWN MODE (2 independent UP-DOWN buttons)

To connect the switch, use only kind of switches with mechanical or electrical interlock, to prevent to press both buttons at same time.

The motor automatically recognizes the switch-type (with 1 or 2 buttons) and sets the proper operational mode.

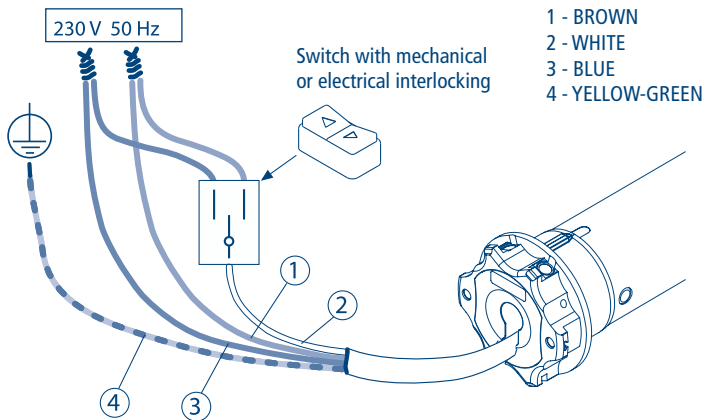

From white wire it's possible to control the motor in the middle position:

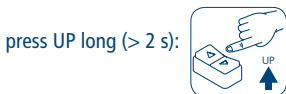

or use the short UP sequence (< 0,5 s) - short DOWN (< 0,5 s)



Using the switch as described on this page it's possible to set the motor trough the white wire (WIRE PROGRAMMING).

To find out this procedure, require the instruction pamphlet from your dealer.

## COMMAND MANAGEMENT FROM WHITE WIRE

### UP-STOP-DOWN-STOP / UP-DOWN / UP-DOWN "DEAD MAN"

NB: The motors leave the factory prepared for use with a single button (UP-STOP-DOWN-STOP operation). You can always change the control type setting by performing the sequence below.

PROCEDURE TO CHANGE THE CONTROL MODE:

Tn: Already programmed remote control

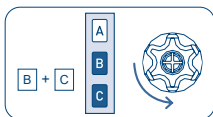

Tn

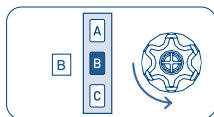

Tn

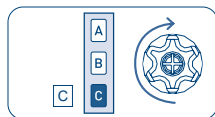

Tn (2 sec)

The possible settings are 3 and are available in the following order:

- UP-STOP-DOWN-STOP (factory setting)
- UP-DOWN (for 2 independent buttons)
- UP-DOWN "DEAD MAN" (for 2 independent buttons)

To switch from one setting to the following, perform the sequence as many times as necessary to reach the desired setting.

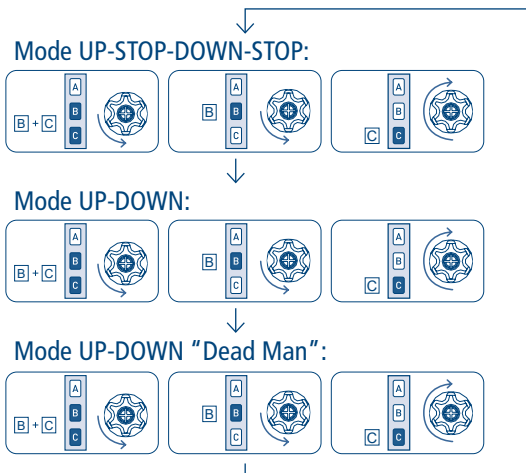

# USING THE MOTOR INTO A Z-WAVE™ NETWORK

## DEVICE DESCRIPTION

INSTA SHORT ZRX is a rolling shutters motor with programmable limit switches, dual-radio control and wired control option.

The dual-radio control allows, on the one hand, the adjustment of the limit switches and the main functions to be carried out simply and interactively and, on the other hand, to be integrated into a Z-Wave™ network.

The wired control option provides for both programming and motor control, from a simple switch, as an addition or as an alternative to the radio remote control. This product operates in any Z-Wave™ network with other Z-Wav™/Z-Wave Plus™ certified devices and controllers from any other manufacturer.

All mains-voltage powered devices act as repeaters, regardless of manufacturer, to increase network reliability.

## Z-WAVE™ TECHNICAL SPECIFICATION

Power supply	230 VAC ±10% 50 Hz
Operating temperature	From -10° to 40° C
Power consumption in stand-by	< 1W
Radio frequency Z-Wave™	868,4 MHz
Radio frequency CRC	433,92 MHz
Protection system	S2 Security
Maximum range Z-Wave™	up to 100 m outdoor up to 40 m indoor
Compliance	CE, RoHs
Electrical IP Rating	IP44

## DEVICE INSTALLATION

- 1) Carry out motor preparation and installation on the rolling shutter
- 2) Wire up the electrical connections
- 3) Program the limit switches and the adjustments as described in the product installation manual.
- 4) Include the device in the Z-Wave™ network

It is advisable to carry out all the preparation, installation and adjustment operations before including the motor in the Z-Wave™ network. Although it is possible to include the motor in a Z-Wave™ network, most features will not be active until the limit switches are adjusted. In particular, the following are not active:

- Movements control and position reporting
- Notifications sending
- Movements requested by "COMMAND\_CLASS\_INDICATOR" class

These limitations are necessary to limit the possibility of damage to the rolling shutter, as well as to protect the safety of the installer.

### INCLUSION/EXCLUSION THE DEVICE INTO/FROM A Z-WAVE™ NETWORK (classic)

INSTA SHORT ZRX is compatible with all Z-Wave™/Z-Wave Plus™ certified controllers. The devices support both the **Network Wide Inclusion** (which offers the ability to be included in a network, even if the device is not directly connected to the controller) and **Standard Inclusion**.

By default setting, the inclusion procedure starts in **Standard Inclusion** mode and after a short timeout the procedure continues in **Network Wide Inclusion** mode that lasts for about 20 Seconds.



## STANDARD INCLUSION (INCLUSION/EXCLUSION)

Make sure that the motor is powered and possibly connected to an up/down button if you wish to use the wired programming sequence, or have a remote control already saved in the motor. Before starting the inclusion process, make sure that the motor is not already included in a Z-Wave™ network; if it is already included, perform the procedure described below: a first time to exclude the motor and then a second time to include it.

The sequence of operations for inclusion/exclusion procedure is as follows:

1) Prepare the Z-Wave™ controller for inclusion (or exclusion) of a device (see your controller's instructions).

2) On the motor, run the programming sequence for inclusion/exclusion:

a. By the remote control: AB – AC – AB (2 seconds), wait for confirmation movements.

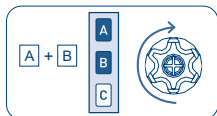
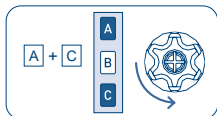
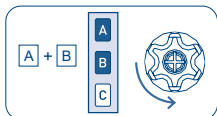

2 sec

b. By the button (if the end stops are not adjusted, you can use either sequence indifferently):

i. With the motor on the high limit switch: UP-UP-UP-UP-UP-DOWN

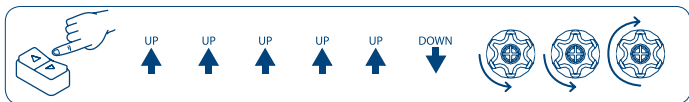

ii. With the motor on the low limit switch: DOWN-DOWN-DOWN-DOWN-DOWN-UP

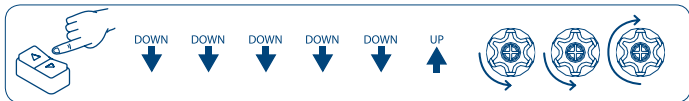

3) The motor performs a few short movements to signal that the inclusion (or exclusion) procedure is in progress.

4) Check the controller to verify that the procedure was successful.

## SMARTSTART INCLUSION

Z-Wave™ SmartStart aims to shift the tasks related to inclusion of an end device into a Z-Wave™ network away from the end device itself, and towards the more user-friendly interface of the gateway.

Z-Wave™ SmartStart removes the need for initiating the end device to start inclusion. Inclusion is initiated automatically on power-ON, and repeated at dynamic intervals for as long as the device is not included into a Z-Wave™ network. As the new device announces itself on power-ON, the protocol provides notifications, and the gateway can initiate the inclusion process in the background, without the need for user interaction or any interruption of normal operation. The SmartStart inclusion process only includes authenticated devices.

INSTA SHORT ZRX can be added to a Z-Wave™ network by scanning the Z-Wave™ QR Code attached to the product with a controller providing SmartStart inclusion. No further action is required and the SmartStart product is added automatically within 10 minutes after being switched on inside the network range.

The QR code and the DSK are shown in numerical format on the label attached to the motor cable. The PIN is the first group of 5 digits printed underlined. To facilitate consultation of these codes, the label has a detachable, self-adhesive part, which can be kept in the instruction manual, or applied in an easily accessible place on the roller shutter (box or final slat).

## S2 SECURE INCLUSION

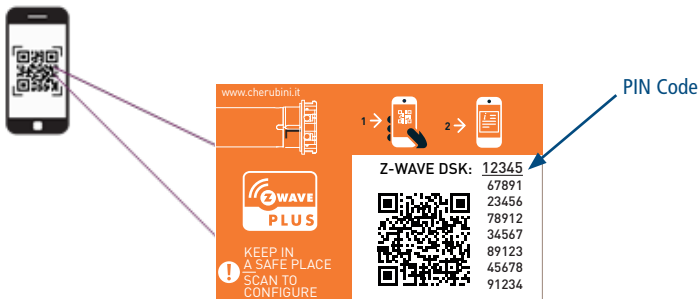

The PIN code of the Z-Wave™ Device Specific Key (DSK) is required when adding the INSTA SHORT ZRX to a Z-Wave™ network with a controller supporting Security 2 Authenticated (S2). The unique DSK code is printed on the product label. The first five digits of the key are highlighted and underlined to help the user identify the PIN code portion of the DSK text.

## DEVICE CONTROL

### CONTROLLING THE MOTOR BY REMOTE AND EXTERNAL SWITCHES

INSTA SHORT ZRX can be controlled by radio remote control and by wired button.

When installing the motor on the rolling shutter, the radio remote control is extremely useful to set the limit switches and perform all programming. After the first installation, the remote control can still be used as a local control point. All information regarding compatible devices and programming methods are described in the product installation manual.

From the remote control, you can execute the basic commands:

- Closing the rolling shutter: press and release the UP button
- Opening the rolling shutter: press and release the DOWN button
- Stop the rolling shutter: press and release the STOP button.

INSTA SHORT ZRX can also be controlled by a wired button, both single and a double-action (up/down).

With the single action button, the operation is as follows:

- Each time the button is pressed/released, the motor will perform the following operations in sequence: Closing, Stopping, Opening, Stopping and so on.

With the double-action button:

- Closing the rolling shutter: press and release the DOWN button
- Opening the rolling shutter: press and release the UP button
- Stop the rolling shutter: press and release the UP or DOWN button while the motor is moving.

Factory default setting:

- No remote control is associated with the motor. The motor can be controlled via a wired button, but until the limit switches are set, it moves in 'dead man' mode: when the button is released, the motor stops.
- As long as the limit switches are not set, the direction of movement of the motor may be reversed, compared to the remote control and the wired double-action button. The direction is correctly identified automatically by the motor itself when the limit switches are set and cannot be changed.

Further information about the operation of the remote control and the wired button can be found in the product installation manual.

## CONTROLLING THE MOTOR WITH A Z-WAVE™ CONTROLLER

INSTA SHORT ZRX can be controlled by any Z-Wave™ / Z-Wave Plus™ certified controller available in the market. In the figure below it's shown how the device will appear once included into the METAHome Controller.

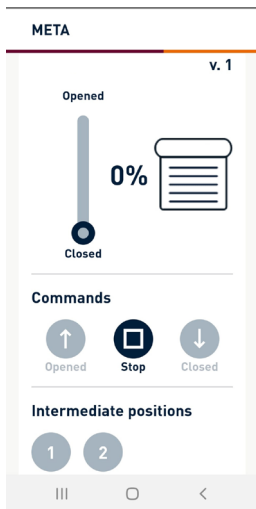

The UP/DOWN/STOP buttons in the control panel allow to Open/Close/Stop the rolling shutter. Using the slider it is possible to set the opening level of the rolling shutter. The device status is updated in case of status change.

## RESET TO THE FACTORY SETTINGS

The Z-Wave™ configuration of the motor can be reset to the original factory values with the following programming sequence:

- 1) From the remote control: AB - AC - BC (4 seconds), wait for confirmation movements to be executed.

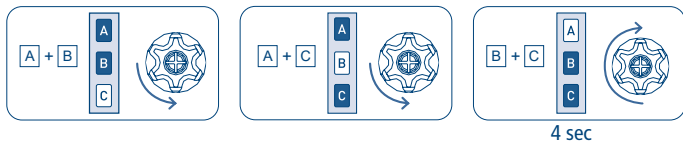

- 2) From the button (if the end stops are not adjusted, you can use either sequence indifferently):

- a. With the motor on the high limit switch: UP-UP-UP-DOWN-UP-DOWN

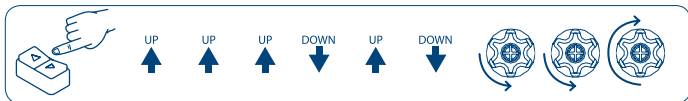

- b. With the motor on the low limit switch: DOWN-DOWN-DOWN-UP-DOWN-UP

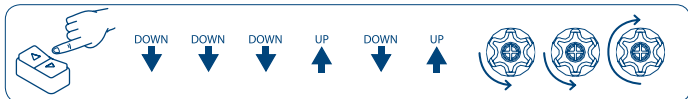

**i** **INFO:** If the reset is performed while the device is still part of a network, it notifies the other devices in the lifeline group that it has been removed (Device Reset Locally Notification).

## FIRMWARE UPDATE

The system supports over-the-air firmware updates that do not require the device to be removed from its location. The firmware update can be activated from all certified controllers supporting version 2 of the Firmware Update function.

**!** **WARNING:** The system will be rebooted at the end of the firmware update procedure. It is advisable to carry out the firmware update procedure only when necessary and following careful planning of the intervention.

## ADVANCED SETTINGS

### SUPPORTED COMMAND CLASSES

Command Class	Version	Non-Secure CC	Secure CC
COMMAND_CLASS_ZWAVEPLUS_INFO	2	x	
COMMAND_CLASS_APPLICATION_STATUS	1	x	
COMMAD_CLASS_INDICATOR	2		x
COMMAND_CLASS_ASSOCIATION	2		x
COMMAND_CLASS_MULTI_CHANNEL_ASSOCIATION	3		x
COMMAND_CLASS_ASSOCIATION_GRP_INFO	2		x
COMMAND_CLASS_TRANSPORT_SERVICE	1	x	
COMMAND_CLASS_VERSION	2		x
COMMAND_CLASS_MANUFACTURER_SPECIFIC	2		x
COMMAND_CLASS_POWERLEVEL	1		x
COMMAND_CLASS_CONFIGURATION	4		x
COMMAND_CLASS_SECURITY_2	1	x	
COMMAND_CLASS_SUPERVISION	1	x	
COMMAND_CLASS_FIRMWARE_UPDATE_MD	5		x
COMMAND_CLASS_BASIC	2		x
COMMAND_CLASS_WINDOW_COVERING	1		x
COMMAND_CLASS_MULTILEVEL	4		x
COMMAND_CLASS_NOTIFICATION	8		x

## “COMMAND\_CLASS\_BASIC” SUPPORT

The device supports Indicator V3 with Indicator ID 0x50 (identity).

## “COMMAND\_CLASS\_INDICATOR” SUPPORT

The device supports Indicator V3 with Indicator ID 0x50 (identity).

When the device receives an indicator set, the motor will perform opening and closing movements of the rolling shutter. The number of movements will be a maximum of 15, with a minimum stroke time of 0.5 s, and a minimum pause time of 0.5 s.

Note: to prevent damage to the slats and the structure of the rolling shutter, movements are only performed if the end switches have been saved.

## “COMMAND\_CLASS\_NOTIFICATION” SUPPORT

The device is able to send a system notification in the event of an obstacle.

Notification Event Code	The meaning associate to the event
3 (System Error Failure)	This notification is sent when the motor reach an obstacle during its operation. The parameter event associate to this event is 1 Byte with the following meaning: 1) collision during opening 0) collision during closing

## ASSOCIATIONS

The device supports 4 association groups, each of which supports the association of up to 5 devices (nodes):

ID del gruppo	Nome del gruppo	N° nodi max	Descrizione	Comando inviato
1	Lifeline	5	Gruppo Life Line	Windows Covering report, Switch Multilevel report, Device Reset Locally Notification, Notification Report, Indicator Report, Configuration Report
2	Follow-me	5	The device in this group will follow the device level.	Basic Set
3	Scene Activation	5	Receive an activation Scene ID if an obstacle are reach during its operation. The scene Id can be define by using parameters 30, 31.	Scene Activation Set

 **INFO:** Association ensures direct transfer of control commands between devices, and is performed without participation of the main controller.

 **TIP:** To avoid network delays, we recommend limiting the amount of associated devices to no more than 5 per group.



## CONFIGURATIONS

### SCENE ACTIVATION

#### Parameter No. 30: OPEN\_COLLISION\_SCENE\_ID (2 byte), simple.

Scene ID sent if a collision is detected during opening operation.

Configuration	Result
0 (Default value)	Do not send the scene activation
From 1 to 254	The scene ID sent for the collision during opening

#### Parameter No. 31: CLOSE\_COLLISION\_SCENE\_ID (2 byte), simple.

Scene ID sent if a collision is detected during closing

Configuration	Result
0 (Default value)	Do not send the scene activation
From 1 to 254	The scene ID sent for the collision during closing

#### Parameter No. 37: LEVEL\_REPORT\_PERIOD (2 byte), advanced.

Used to define the level report frequency when the motor is moving. Valid values are from 2 (report updated every 2 seconds) to 60 (report updated every 60 seconds).

Configuration	Result
From 2 to 60	Time between reports in seconds
5 (Default value)	

#### Parameter No. 38: SEND\_MULTILEVEL\_REPORT (1 byte), advanced.

For backward compatibility the device can send the multilevel report together with the Switch Multilevel report in addition to the update with Windows Covering report.

Configuration	Result
0 (Default value)	Multilevel report will not be sent
1	Multilevel report will be sent

## **IT DICHIARAZIONE DI CONFORMITÀ UE**

**CE** CHERUBINI S.p.A. dichiara che il prodotto è conforme alle pertinenti normative di armonizzazione dell'Unione:

Direttiva 2014/53/UE, Direttiva 2011/65/UE.

Il testo completo della dichiarazione di conformità UE è disponibile facendone richiesta sul sito: [www.cherubini.it](http://www.cherubini.it).

## **EN EU DECLARATION OF CONFORMITY**

**CE** CHERUBINI S.p.A. declares that the product is in conformity with the relevant Union harmonisation legislation:

Directive 2014/53/EU, Directive 2011/65/EU.

The full text of the EU declaration of conformity is available upon request at the following website: [www.cherubini.it](http://www.cherubini.it).

## **DE EU-KONFORMITÄTSERKLÄRUNG**

**CE** CHERUBINI S.p.A. erklärt der produkt erfüllt die einschlägigen Harmonisierungsrechtsvorschriften der Union:

Richtlinie 2014/53/EU, Richtlinie 2011/65/EU.

Der vollständige Text der EU-Konformitätserklärung kann unter unserer Web-Seite [www.cherubini.it](http://www.cherubini.it), gefragt werden.

## **FR DÉCLARATION UE DE CONFORMITÉ**

**CE** CHERUBINI S.p.A. déclare que le produit est conforme à la législation d'harmonisation de l'Union applicable:

Directive 2014/53/UE, Directive 2011/65/UE.

Le texte complet de la déclaration UE de conformité est disponible en faisant requête sur le site internet: [www.cherubini.it](http://www.cherubini.it).

## **ES DECLARACIÓN UE DE CONFORMIDAD**

**CE** CHERUBINI S.p.A. declara que el producto es conforme con la legislación de armonización pertinente de la Unión:

Diretiva 2014/53/UE, Directiva 2011/65/UE.

El texto completo de la declaración UE de conformidad puede ser solicitado en: [www.cherubini.it](http://www.cherubini.it).



**CHERUBINI S.p.A.**

Via Adige 55  
25081 Bedizzole (BS) - Italy  
Tel. +39 030 6872.039 | Fax +39 030 6872.040  
info@cherubini.it | www.cherubini.it

**CHERUBINI Iberia S.L.**

Avda. Unión Europea 11-H  
Apdo. 283 - P. I. El Castillo  
03630 Sax Alicante - Spain  
Tel. +34 (0) 966 967 504 | Fax +34 (0) 966 967 505  
info@cherubini.es | www.cherubini.es

**CHERUBINI France SAS**

ZI Du Mas Barbet  
165 Impasse Ampère  
30600 Vauvert - France  
Tél. +33 (0) 466 77 88 58  
info@cherubini.fr | www.cherubini.fr

**CHERUBINI Deutschland GmbH**

Siemensstrasse, 40 - 53121 Bonn - Deutschland  
Tel. +49 (0) 228 962 976 34 / 35 | Fax +49 (0) 228 962 976 36  
info@cherubini-group.de | www.cherubini-group.de

